



**SFP-10G-BXD-I-ECO**  
**SFP-10G-BXU-I-ECO**  
10GBASE-BX10-D,SFP+  
1330nm-TX/1270nm-RX  
&1270nm-TX/1330nm-RX,SMF,  
10km, Dual LC, DOM for Cisco

## SFP-10G-BXD-I-ECO

## SFP-10G-BXU-I-ECO

10Gb/s WDM SFP+Transceiver

Hot Pluggable, Duplex LC, +3.3V, 1270nm/1330nm, CWDM DFB  
10km DDM

### Features

- Supports 9.95Gb/s to 11.3Gb/s bit rates
- Hot-pluggable SFP+ footprint
- Single LC for Bi-directional Transmission
- Maximum link length of 10km
- Built-in 1270/1330 WDM Filter
- Uncooled 1270nm or 1330nm CWDM DFB Laser.
- Power dissipation <1.5W
- No Reference Clock required
- Built-in digital diagnostic functions
- Temperature range 0°C to 70°C, -40~85°C is available
- Very low EMI and excellent ESD protection
- RoHS Compliant Part

### Applications

- 10GBASE-LR/LW Ethernet
- SONET OC-192 / SDH
- 10G Fibre Channel



**SFP-10G-BXD-I-ECO**  
**SFP-10G-BXU-I-ECO**  
10GBASE-BX10-D,SFP+  
1330nm-TX/1270nm-RX  
&1270nm-TX/1330nm-RX,SMF,  
10km, Dual LC, DOM for Cisco

## Description

ARPERS **SFP-10G-BXD-I-ECO/ SFP-10G-BXU-I-ECO** Bi-directional 10Gb/s (SFP+) transceivers are compliant with the current SFP+ Multi-Source Agreement (MSA) Specification. They comply with 10GBASE-LR/LW Ethernet, SONET OC-192 / SDH and 10G Fibre Channel 1200-SM-LL-L. Digital diagnostics functions are available via a 2-wire serial interface, as specified in the SFP+ MSA

## Absolute Maximum Ratings

Parameter	Symbol	Min	Typical	Max.	Unit
Storage Temperature	T <sub>S</sub>	-40		+85	°C
Supply Voltage	V <sub>CCT, R</sub>	-0.5		4	V
Relative Humidity	RH	0		85	%

## Recommended Operating Environment:

Parameter	Symbol	Min.	Typical	Max.	Unit
Case operating Temperature	T <sub>C</sub>	-5		+70	°C
Supply Voltage	V <sub>CCT, R</sub>	+3.13 5		+3.46 5	V
Supply Current	I <sub>CC</sub>			350	mA
Power Dissipation	P <sub>D</sub>			1.5	W

**Electrical Characteristics (TOP = 0 to 70 °C, VCC = 3.135 to 3.465 Volts)**

Parameter	Symbol	Min	Typ	Max	Unit	Note	
<b>Transmitter:</b>							
Differential input voltage swing		180		700	mVp p	1	
Transmit Disable Input	H	V <sub>IH</sub>	2.0		V <sub>CC</sub> +0.3	V	
	L	V <sub>IL</sub>	0		0.8	V	
Transmit Enable Output	H	V <sub>OH</sub>	2.4		V <sub>CC</sub> +0.3	V	
	L	V <sub>OL</sub>	0		0.4	V	2
Input Differential Impedance	Z <sub>in</sub>	80	100	120	Ω		
<b>Receiver</b>							
Differential output voltage swing		300		850	mVp p	3	
LOS Output	H	V <sub>OH</sub>	2.4		V <sub>CC</sub> +0.3	V	2
	L	V <sub>OL</sub>	0		0.4	V	
Output Differential Impedance	Z <sub>on</sub>	80	100	120	Ω		

**Notes:**

- Note 1) TD+/- are internally AC coupled with 100Ω differential termination inside the module. Note 2) Tx Fault and Rx LOS are open collector outputs, which should be pulled up with 4.7k to 10kΩ resistors on the host board. Pull up voltage between 2.0V and V<sub>CC</sub>+0.3V. Note 3) RD+/- outputs are internally AC coupled, and should be terminated with 100 Ω (differential) at the user SERDES.

**Optical Parameters(TOP = 0 to 70°C, VCC = 3.135 to 3.465 Volts)**

Parameter	Symbol	Min	Typ	Max	Unit	Ref.	
<b>Transmitter</b>							
Bit Rate	BR	9.9		1.3	Gb/s		
Optical Wavelength	SFP-10G-BXD-I-EC O	λ	1260	1270	1280	nm	
	SFP-10G-BXU-I-EC O		1320	1330	1340		
Average output power	Po	-6		-1	dBm		
Optical Extinction Ratio	ER	3.5			dB		
Spectral width	Δλ			1	nm		
Side Mode Suppression Ratio	SMSR	30			dB		
Optical Eye Mask		Compliant with IEEE802.3ae					
<b>Receiver</b>							
Bit Rate	BR	9.9		1.3	Gb/s		
Optical Wavelength	SFP-10G-BXD-I-EC O	λ	1320	1330	1340	nm	
	SFP-10G-BXU-I-EC O		1260	1270	1280		
Receiver Sensitivity	Sen			-14.5	dBm	1	
Maximum Input Power	P <sub>MAX</sub>	0			dBm		
LOS De-Assert	LOSD			-15	dBm		
LOS Assert	LOSA	-25			dBm		
LOS Hysteresis	LOSH	0.5		4	dB		

**Notes:**

Note 1) Measured with a PRBS of  $2^{31}-1$  at  $1 \times 10^{-12}$  BER and 3.5 dB extinction ratio.

## Pin Assignment

Diagram of Host Board Connector Block Pin Numbers and Name

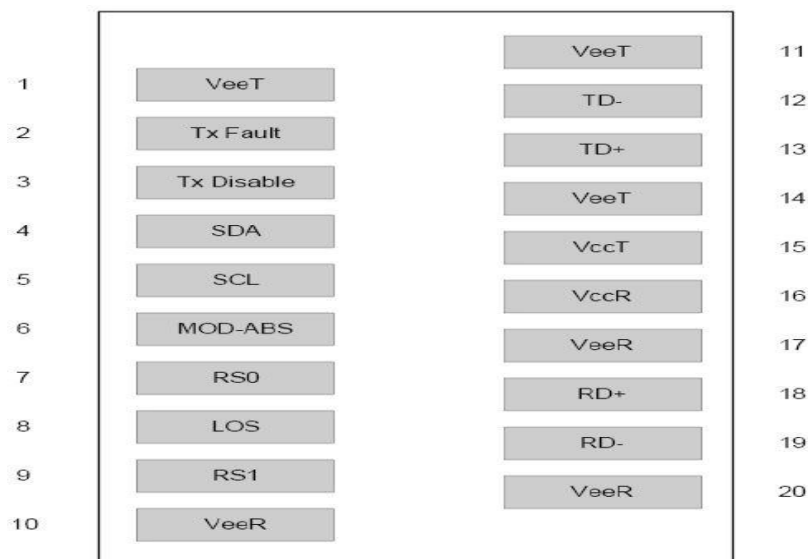

## Pin Function Definitions

PIN #	Name	Function	Notes
1	VeeT	Module transmitter ground	1
2	Tx Fault	Module transmitter fault	2
3	Tx Disable	Transmitter Disable; Turns off transmitter laser output	3
4	SDL	2 wire serial interface data input/output (SDA)	
5	SCL	2 wire serial interface clock input (SCL)	
6	MOD-ABS	Module Absent, connect to VeeR or VeeT in the module	2
7	RS0	Rate select0, optionally control SFP+ receiver. When high, input data rate >4.5Gb/s; when low, input data rate <=4.5Gb/s	
8	LOS	Receiver Loss of Signal Indication	4
9	RS1	Rate select0, optionally control SFP+ transmitter. When high, input data rate >4.5Gb/s; when low, input data rate <=4.5Gb/s	
10	VeeR	Module receiver ground	1
1	VeeR	Module receiver ground	1
12	RD-	Receiver inverted data out put	

13	RD+	Receiver non-inverted data out put	
14	VeeR	Module receiver ground	1
15	VccR	Module receiver 3.3V supply	
16	VccT	Module transmitter 3.3V supply	
17	VeeT	Module transmitter ground	1
18	TD+	Transmitter inverted data out put	
19	TD-	Transmitter non-inverted data out put	
20	VeeT	Module transmitter ground	1

**Notes:**

Note 1) The module ground pins shall be isolated from the module case.

Note 2) This pin is an open collector/drain output pin and shall be pulled up with 4.7K- 10Kohms to Host\_Vcc on the host board.

Note 3) This pin shall be pulled up with 4.7K-10Kohms to VccT in the module.

Note 4) This pin is an open collector/drain output pin and shall be pulled up with 4.7K- 10Kohms to Host\_Vcc on the host board.

**SFP Module EEPROM Information and Management**

The SFP modules implement the 2-wire serial communication protocol as defined in the SFP -8472. The serial ID information of the SFP modules and Digital Diagnostic Monitor parameters can be accessed through the I<sup>2</sup>C interface at address A0h and A2h. The memory is mapped in Table 1. Detailed ID information (A0h) is listed in Table 2. And the DDM specification at address A2h. For more details of the memory map and byte definitions, please refer to the SFF-8472, “ Digital Diagnostic Monitoring Interface for Optical Transceivers”. The DDM parameters have been internally calibrated.

**Table 1. Digital Diagnostic Memory Map (Specific Data Field Descriptions)**

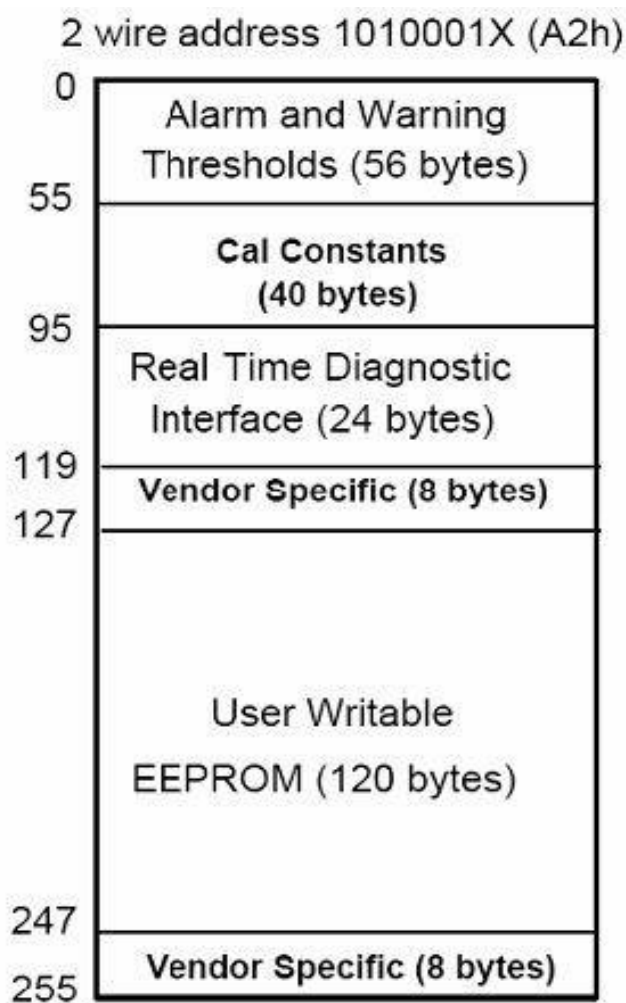
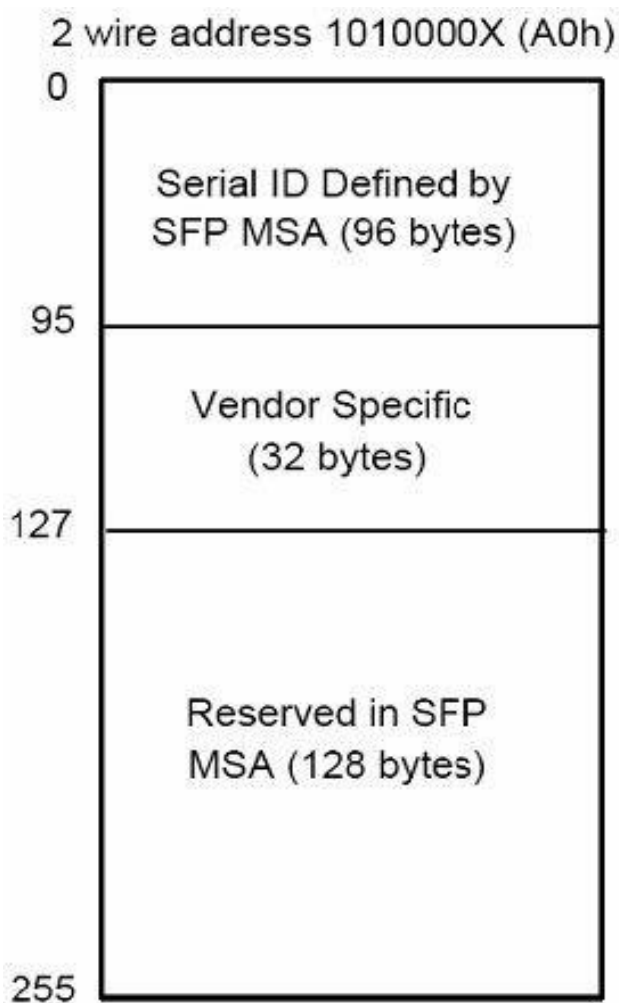

**Table 2 - EEPROM Serial ID Memory Contents (A0h)**

Data Address	Length (Byte)	Name of Length	Description and Contents
<b>Base ID Fields</b>			
0	1	Identifier	Type of Serial transceiver (03h=SFP)
1	1	Reserved	Extended identifier of type serial transceiver (04h)
2	1	Connector	Code of optical connector type (07=LC)
3-10	8	Transceiver	10G Base-LR
11	1	Encoding	64B/66B
12	1	BR, Nominal	Nominal baud rate, unit of 100Mbps
13-14	2	Reserved	(0000h)
15	1	Length(9um)	Link length supported for 9/125um fiber, units of 100m
16	1	Length(50um )	Link length supported for 50/125um fiber, units of 10m
17	1	Length(62.5um )	Link length supported for 62.5/125um fiber, units of 10m
18	1	Length(Copper)	Link length supported for copper, units of meters
19	1	Reserved	
20-35	16	Vendor Name	SFP vendor name: ARPERS
36	1	Reserved	
37-39	3	Vendor OUI	SFP transceiver vendor OUI ID
40-55	16	Vendor PN	Part Number: “SFP-10G-BXD-I-ECO” or “SFP-10G-BXU-I-ECO” (ASCII)
56-59	4	Vendor rev	Revision level for part number
60-62	3	Reserved	
63	1	CCID	Least significant byte of sum of data in address 0-62
<b>Extended ID Fields</b>			
64-65	2	Option	Indicates which optical SFP signals are implemented (001Ah = LOS, TX_FAULT, TX_DISABLE all supported)
66	1	BR, max	Upper bit rate margin, units of %
67	1	BR, min	Lower bit rate margin, units of %
68-83	16	Vendor SN	Serial number (ASCII)
84-91	8	Date code	ARPERS Manufacturing date code





**SFP-10G-BXD-I-ECO**  
**SFP-10G-BXU-I-ECO**  
 10GBASE-BX10-D,SFP+  
 1330nm-TX/1270nm-RX  
 &1270nm-TX/1330nm-RX,SMF,  
 10km, Dual LC, DOM for Cisco

92-94	3	Reserved	
95	1	CCEX	Check code for the extended ID Fields (addresses 64 to 94)
Vendor Specific ID Fields			
96-127	32	Readable	ARPERS specific date, read only
128-255	12 8	Reserved	Reserved for SFF-8079

### Digital Diagnostic Monitor Characteristics

Data Address	Parameter	Accuracy	Unit
96-97	Transceiver Internal Temperature	±3.0	°C
100-101	Laser Bias Current	±10	%
100-101	Tx Output Power	±3.0	dBm
100-101	Rx Input Power	±3.0	dBm
100-101	VCC3 Internal Supply Voltage	±3.0	%

### Regulatory Compliance

The SFP-10G-BXD-I-ECO/ SFP-10G-BXU-I-ECO complies with international Electromagnetic Compatibility (EMC) and international safety requirements and standards (see details in Table following).

Electrostatic Discharge (ESD) to the Electrical Pins	MIL-STD-883E Method 3015.7	Class 1(>1000 V)
Electrostatic Discharge (ESD) to the Single LC Receptacle	IEC 61000-4-2 GR-1089-CORE	Compatible with standards
Electromagnetic Interference (EMI)	FCC Part 15 Class B EN55022 Class B (CISPR 22B) VCCI Class B	Compatible with standards
Laser Eye Safety	FDA 21CFR 1040.10 and 1040.11 EN60950, EN (IEC) 60825-1,2	Compatible with Class 1 laser product.

### Recommended Circuit

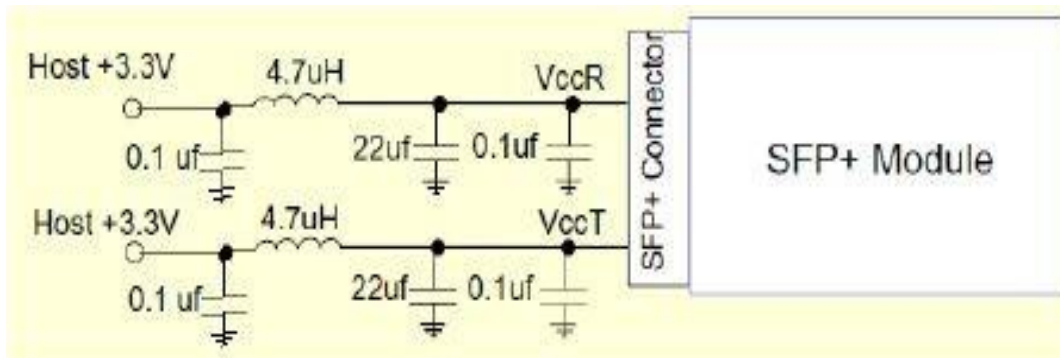

Recommended Host Board Power Supply Circuit

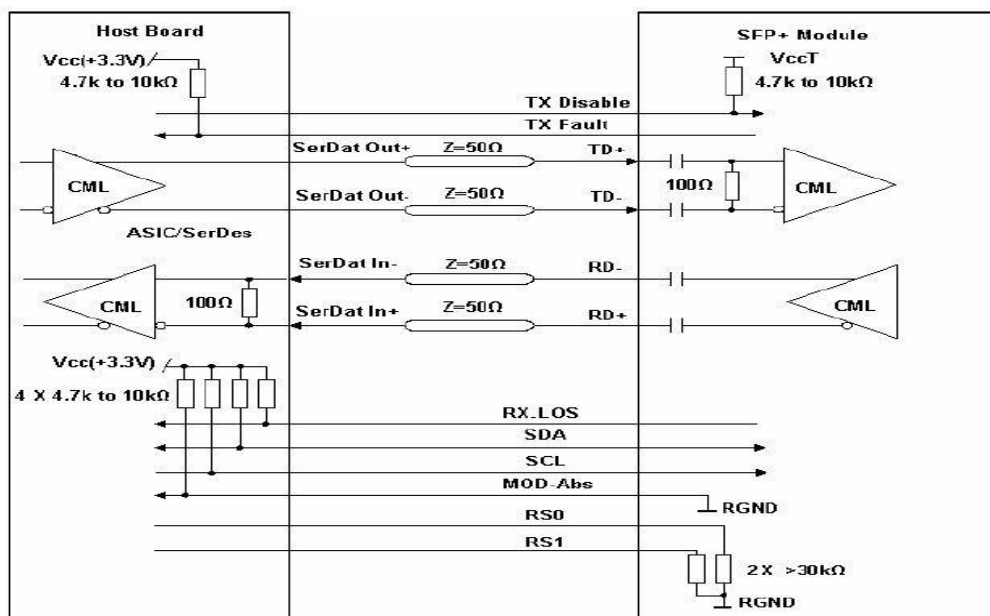

Recommended High-speed Interface Circuit

**SFP-10G-BXD-I-ECO**  
**SFP-10G-BXU-I-ECO**  
10GBASE-BX10-D,SFP+  
1330nm-TX/1270nm-RX  
&1270nm-TX/1330nm-RX,SMF,  
10km, Dual LC, DOM for Cisco

**Mechanical Dimensions**

