

Arpers' **GLC-BX80-D-I-COM** is programmed to be fully compatible and functional with all intended Cisco switching devices. This SFP optical transceiver is designed for IEEE 802.3 Gigabit Ethernet interconnects and is designed to be compliant with SFF-8472 SFP Multi-source Agreement (MSA). This module is designed for single mode simplex fiber and operates at a nominal transmit wavelength of 1550nm and nominal receive wavelength of 1490nm.

Features:

- Up to 1.25GBd bi-directional data links
- Hot- pluggable SFP footprint
- 1550nm DFB laser transmitter
Simplex LC Connectors
- Built in Digital Diagnostics
- Up to 80km over 9/125 SMF
- Single power supply 3.3V
- Operating temperature range C-Temp: 0°C to 70°C



Compliance:

- IEEE 802.3z Gigabit Ethernet
SFP MSA SFF-8472
- RoHS
- Class 1 laser product EN 60825

Applications

- 1.25GBd Gigabit Ethernet

Warranty:

Optical Transceivers-Lifetime Warranty

General Specifications

Parameter	Symbol	Min	Typ	Max	Unit	Remarks
Data Rate	DR		1.25		GBd	IEEE 802.3
Bit Error Rate	BER			10 ⁻¹²		
Input Voltage	V _{CC}	3	3.3	3.6	V	
Maximum Voltage	V _{max}	-0.5		4	V	Electric Power Interface
Supply Current	I _s		230	300	mA	Electric Power Interface
Storage Temperature	T _{sto}	-40		85	°C	Ambient Temperature

Optical Characteristics - Transmitter

Parameter	Symbol	Min	Typ	Max	Unit	Remarks
Optical Center Wavelength	λ	1540	1550	1560	nm	
Output Optical Power	P _{tx}	0		5	dBm	Class 1 Product
Optical Modulation Amp	OMA	174			uW	
Extinction Ratio @ 1.25GBd	ER	9			dB	
Spectral Width (-20dB)				1	nm	
Relative Intensity Noise	RIN			-120	dB/Hz	
Optical Rise/Fall Time	T _{RF_IN}		150	260	ps	
Deterministic Jitter Contribute	TX_DJ		30	60	ps	
Total Jitter Contribution	TX_TJ		60	120	ps	

Optical Characteristics - Receiver

Parameter	Symbol	Min	Typ	Max	Unit	Remarks
Optical Center Wavelength	λ_c	1480	1490	1500	nm	
Optical Receive Power	P _{RX}			0	dBm	Average
Receiver Sensitivity @ 1.25GBd	P _{SENSI}			-25	dBm	IEEE 802.3
Optical Return Loss	ORL	14			dB	
Optical Isolation	ISO			-40	dB	
LOS Assert	LOS _A	-30			dBm	
LOS De-Assert	LOS _D			-23	dBm	
LOS Hysteresis		0.5			dB	

Electrical Characteristics – Transmitter

Parameter	Symbol	Min	Typ	Max	Unit	Remarks
Input differential impedance	R _{in}		100		Ω	Non Condensing
Single ended data input swing	V _{IN_PP}	250		1200	mV	
Transmit Disable Voltage	V _D	V _{CC} -1.3		V _{CC}	V	
Transmit Enable Voltage	V _{EN}	V _{EE}		V _{EE} +0.8	V	
Transmit Disable Assert Time				10	us	

Electrical Characteristics – Receiver

Parameter	Symbol	Min	Typ	Max	Unit	Remarks
Single ended data output swing	V_{OUT_PP}	300	400	800	mV	
Data output rise/fall time	T_R			300	ps	20%-80%
LOS Fault	V_{LOS_F}	$V_{CC}-0.5$		V_{CC_HOST}	V	
LOS Normal	V_{LOS_N}	V_{EE}		$V_{EE}+0.5$	V	

Digital Diagnostic Functions

The SFP support the 2-wire serial communication protocol as defined in the SFF 8472. Digital diagnostic information are accessible over the 2-wire interface at the address 0xA2. Digital Diagnostics are internally calibrated by default. A micro controller unit inside the transceiver gathers the monitoring information and reports the status of transceiver.

Transceiver Temperature- Internally measured, represented as a 16 bit signed twos complement value in increments of 1/256 degrees Celsius, Temperature accuracy is better than ± 3 degrees Celsius over specified operating temperature and voltage.

Transceiver Supply Power- Internally measured, represented as a 16 bit unsigned integer with the voltage defined as the full 16 bit value (0 – 65535) with LSB equal to 100 μ Volt, yielding a total range of 0 to +6.55 Volts.

Transceiver TX bias current- Internally measured, represented as a 16 bit unsigned integer with the current defined as the full 16 bit value (0 – 65535) with LSB equal to 2 μ A, yielding a total range of 0 to 131mA. Accuracy is better than $\pm 10\%$ over specified operating temperature and voltage.

Transceiver TX output power- Internally measured, represented as a 16 bit unsigned integer with the power defined as the full 16 bit value (0 – 65535) with LSB equal to 0.1 μ W. Data is assumed to be based on measurement of laser monitor photodiode current. Accuracy is better than ± 3 dB over specified temperature and voltage. Data is not valid when the transmitter is disabled.

Transceiver RX received optical power- Internally measured, represented as a 16 bit unsigned integer with the power defined as the full 16 bit 35 value (0 – 65535) with LSB equal to 0.1 μ W. Accuracy is better than ± 3 dB over specified temperature and voltage.

Parameter	Symbol	Accuracy	Units	Report Range	Unit	Remarks
Temperature	T_{mon}	± 3	$^{\circ}$ C	-40 - +95	$^{\circ}$ C	
Voltage	V_{mon}	± 0.1	V	2.9 - 3.7	V	
Bias Current	T_F	± 10	%	1 - 80	mA	
Tx Power	V_{LOS_F}	± 3	dB	-10 - 5	dBm	
Rx Power	V_{LOS_N}	± 3	dB	-30 - 0	dBm	

Mechanical Dimensions

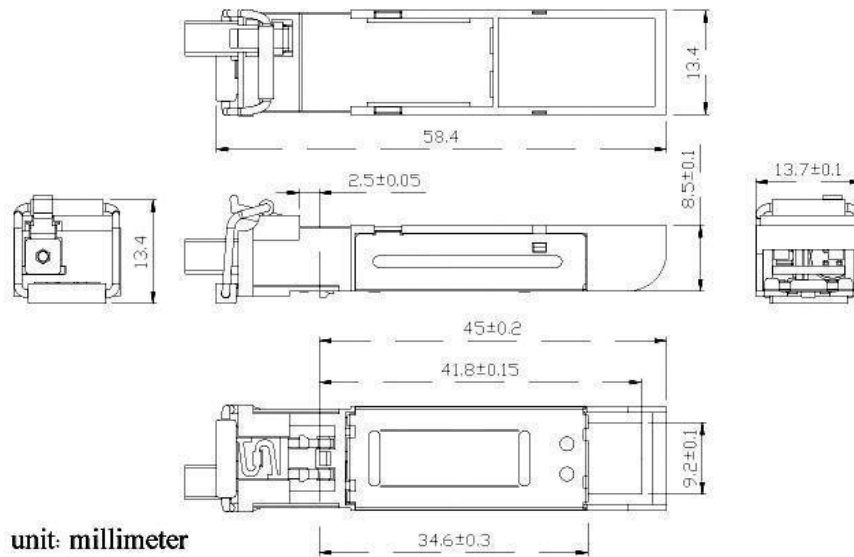

ALL DIMENSIONS ARE ±0.2mm UNLESS OTHERWISE SPECIFIED

Block Diagram of the Transceiver

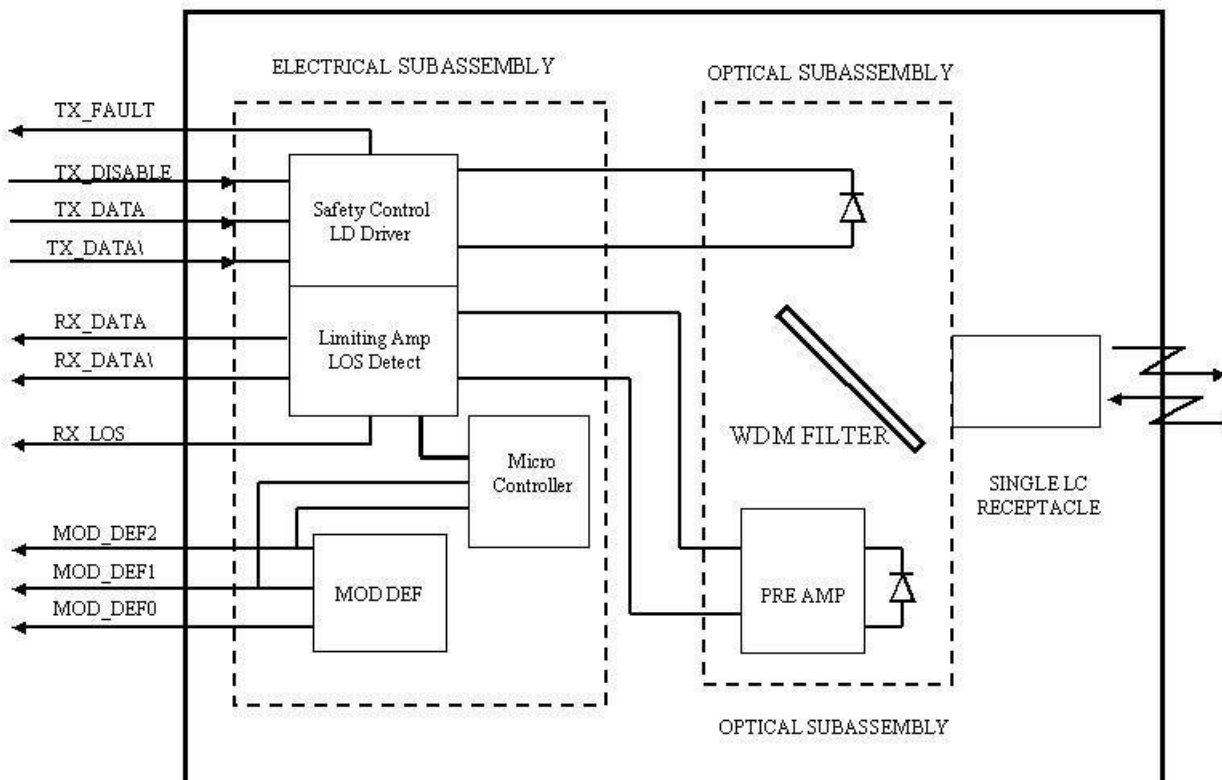

Transmitter Section

The VCSEL driver accept differential input data and provide bias and modulation currents for driving a laser. An automatic power-control (APC) feedback loop is incorporated to maintain a constant average optical power. 1310nm Fabry-Perot laser in an eye safe optical subassembly (OSA) mates to the fiber cable.

TX_DISABLE- The TX_DISABLE signal is high (TTL logic "1") to turn off the laser output. The laser will turn on within 1ms when TX_DISABLE is low (TTL logic "0").

TX_FAULT- When the TX_FAULT signal is high, output indicates a laser fault of some kind. Low indicates normal operation.

Receiver Section

- The receiver utilizes a PIN detector integrated with a trans-impedance preamplifier in an OSA. This OSA is connected to a Limiting Amplifier which providing post-amplification quantization, and optical signal detection. The limiting Amplifier is AC-coupled to the transimpedance amplifier, with internal 100Ω differential termination.

Receive Loss (RX_LOS)- The RX_LOS is high (logic "1") when there is no incoming light from the companion transceiver. This signal is normally used by the system for the diagnostic purpose. The signal is operated in TTL level.

Controller Section- The micro controller unit monitors the operation information of LD driver and Limiting Amplifier and report these statuses to the customer

PCB Layout Recommendation

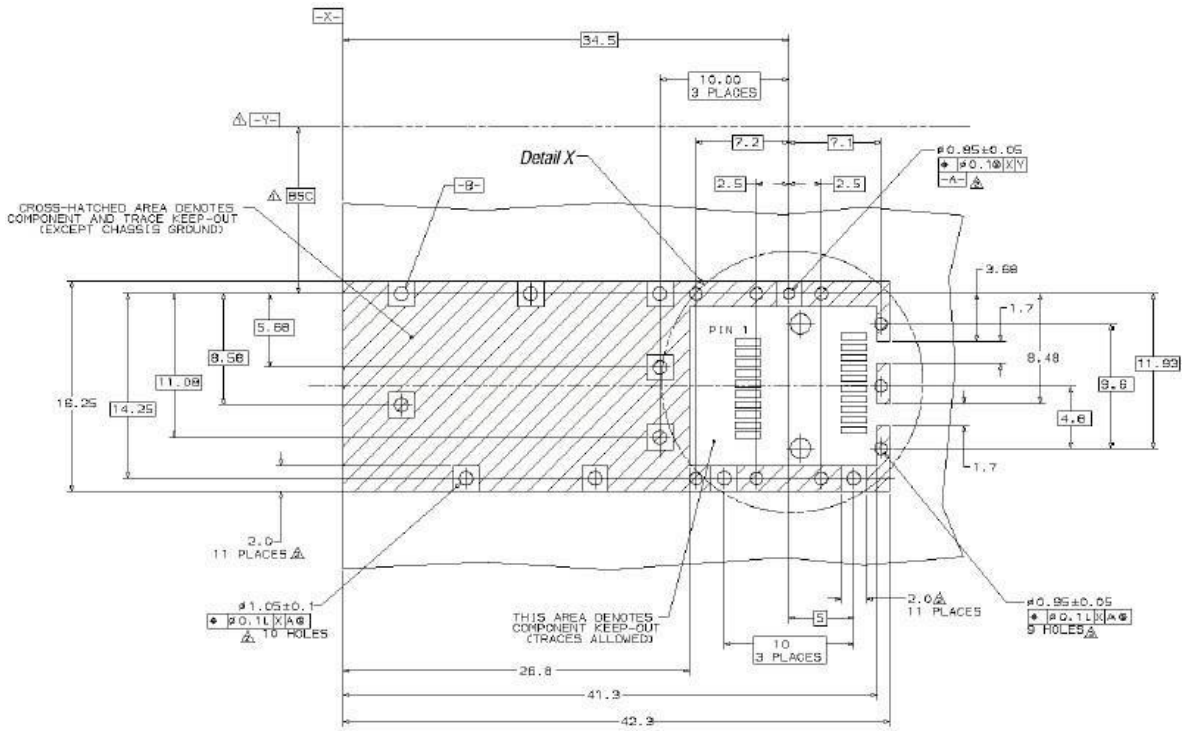

△ Datum and Basic Dimension Established by Customer

△ Rads and Vias are Chassis Ground, 11 Places

△ Through Holes are Unplated

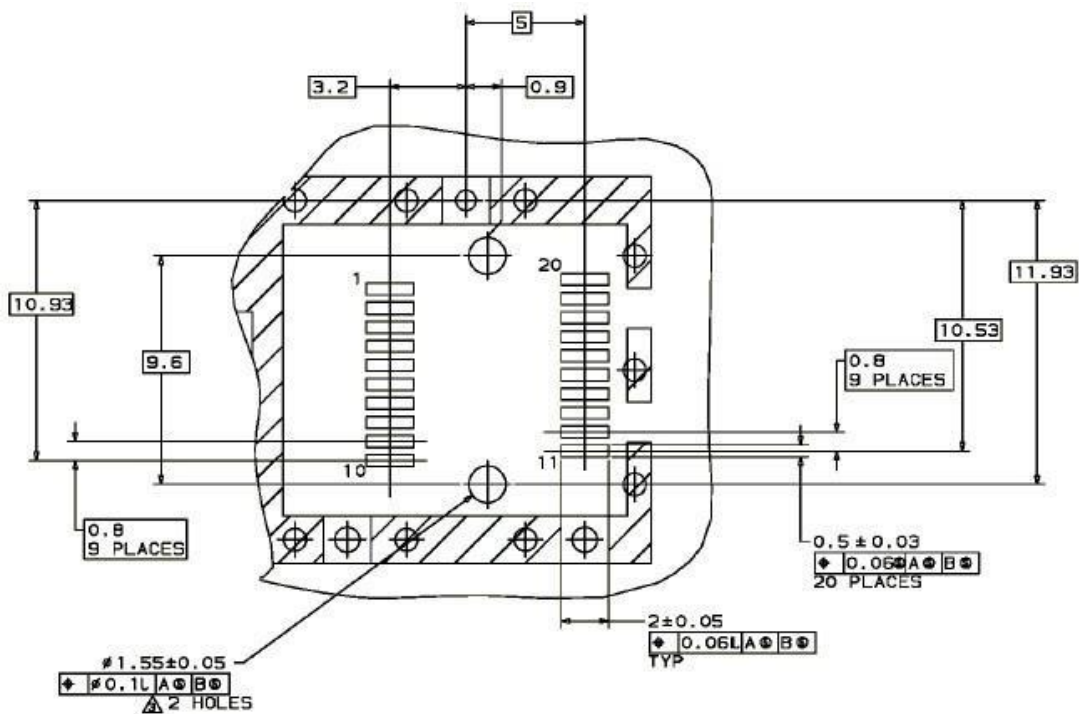

Electric Pad layout

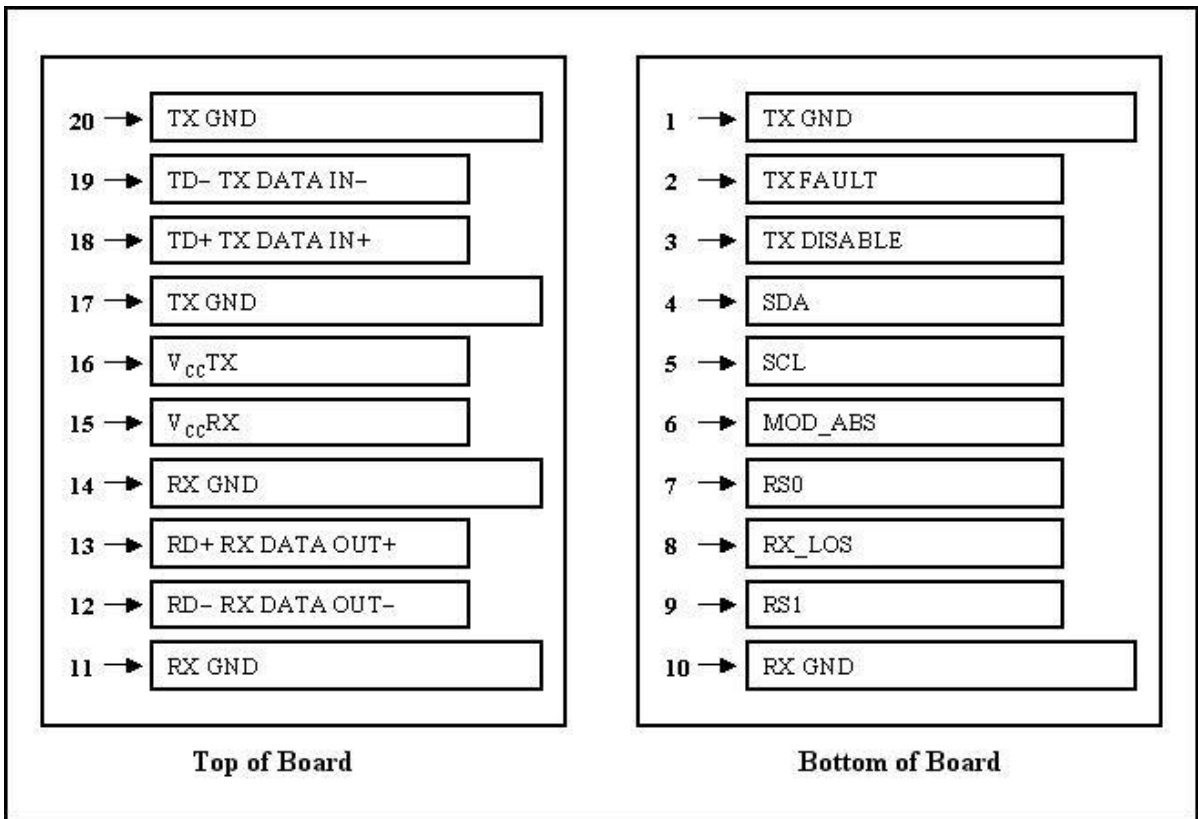
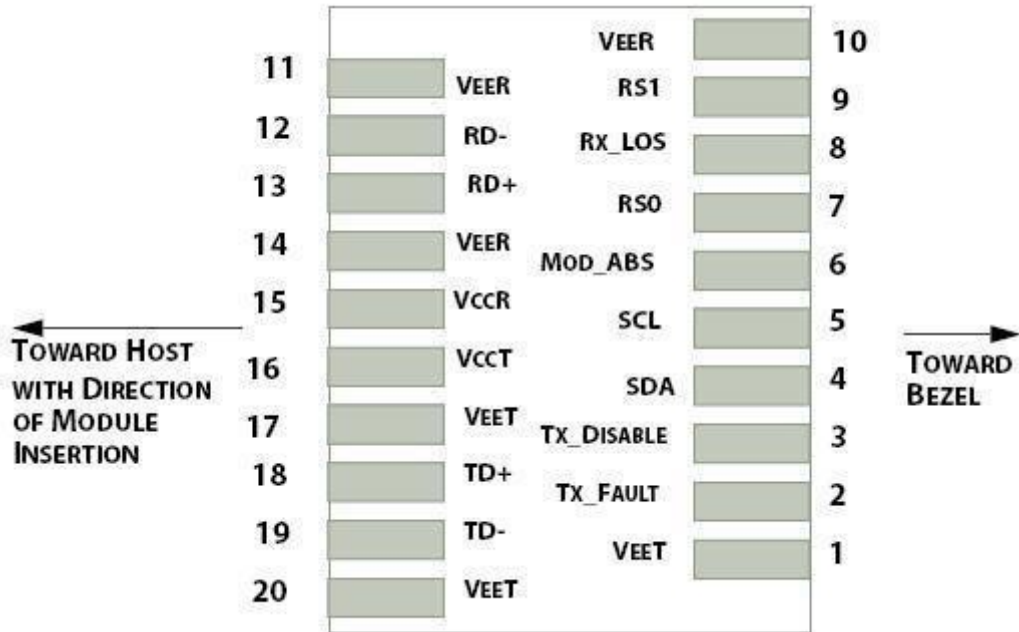

Pin Assignement

<i>PIN #</i>	<i>Symbol</i>	<i>Description</i>	<i>Remarks</i>
1	VEET	Transmitter ground (common with receiver ground)	Circuit ground is isolated from chassis ground
2	TFAULT	Transmitter Fault	
3	TDIS	Transmitter Disable. Laser output disable on high or open	Disabled: TDIS>2V or open Enabled: TDIS<0.8V
4	SDA	Data line for serial ID	Should Be pulled up with
5	SCL	Clock line for serial ID	4.7k – 10k ohm on host
6	MOD_ABS	Module Absent. Ground within the module	board to a voltage between 2V and 3.6V
7	RS0	No Connection required	
8	LOS	Loss of Signal indication. Logic 0 indicates normal operation	LOS is open collector output
9	RS1	+3.3V Power Supply	Circuit ground is isolated from chassis ground
10	VEER	Receiver ground (common with transmitter ground)	
11	VEER	Receiver ground (common with transmitter ground)	
12	RD-	Receiver Inverted DATA out. AC coupled	
13	RD+	Receiver Non-inverted DATA out. AC coupled	
14	VEER	Receiver ground (common with transmitter ground)	Circuit ground is isolated from chassis ground
15	VCCR	Receiver power supply	
16	VCCT	Transmitter power supply	Same as Pin# 1
17	VEET	Transmitter ground (common with receiver ground)	Circuit ground is connected to chassis ground
18	TD+	Transmitter Non-inverted DATA out. AC coupled	
19	TD-	Transmitter Inverted DATA out. AC coupled	
20	VEET	Transmitter ground (common with receiver ground)	Circuit ground is connected to chassis ground

References

1. IEEE standard 802.3. IEEE Standard Department, 2002.
2. Small Form Factor Pluggable (SFP) Transceiver Multi-Source Agreement (MSA), September 2000.
3. Digital Diagnostics Monitoring Interface for Optical Transceivers – SFF-8472.